

UE-ADPL Series Ultraviolet Light System

APPLICATION:

The UE-ADPL Series is intended for use in Split-System HVAC units from 5 to 10 tons. These units are ideal for destroying airborne virus and bacteria moving through the system, and spore growth (mold) growing on coils, drain pans and UV compatible filters. Optional PCO grid removes VOC's (the cause of common household odors).

- Small split system HVAC units (light commercial or residential).
- Installed at the coil plenum.
- Work 24/7 to keep air free and clear of airborne contaminants.
- Are engineered to maintain high level air disinfection 24/7 by neutralizing and eliminating the infectious airborne pathogens that cause respiratory illness and disease.
- Designed to achieve disinfection of the cooling coil surfaces to increase efficiency and decrease biological growth on the coil.

STANDARD CONSTRUCTION:

Housing: Aluminum with 9ft. power cord, LED power indicator light, On/Off rocker switch

Lamp: 35 nom. watts; 105 $\mu\text{W}/\text{cm}^2$ @ 1 meter (ADPL-UE _35 series)
 60 nom. watts; 180 $\mu\text{W}/\text{cm}^2$ @ 1 meter (ADPL-UE _60 series)
 95 nom. watts; 275 $\mu\text{W}/\text{cm}^2$ @ 1 meter (ADPL-UE _95 series)

Electrical Requirement: (each unit) 120V/1.3A to 240V/0.56A; 50-60Hz

Optional: PCO grid (to eliminate VOC's)

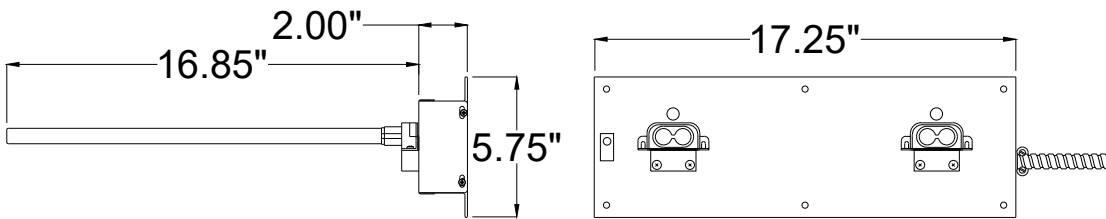
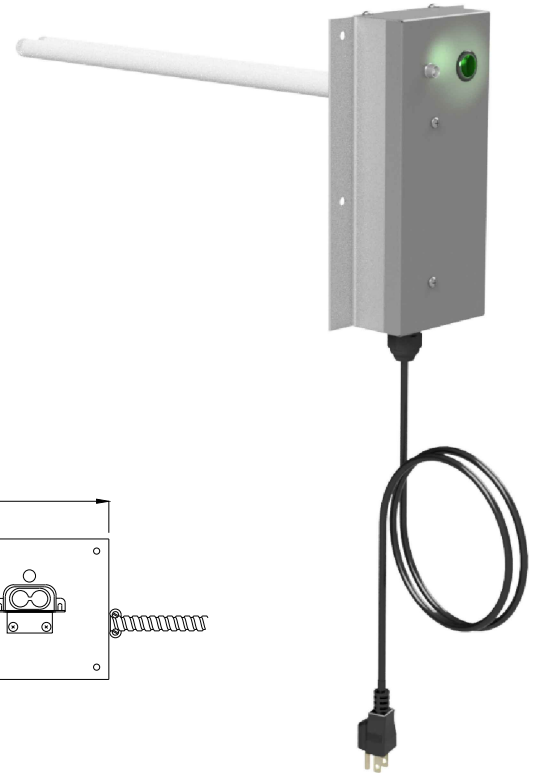

UE ADPL-235/260/295

UE-ADPL Series Ordering Information:

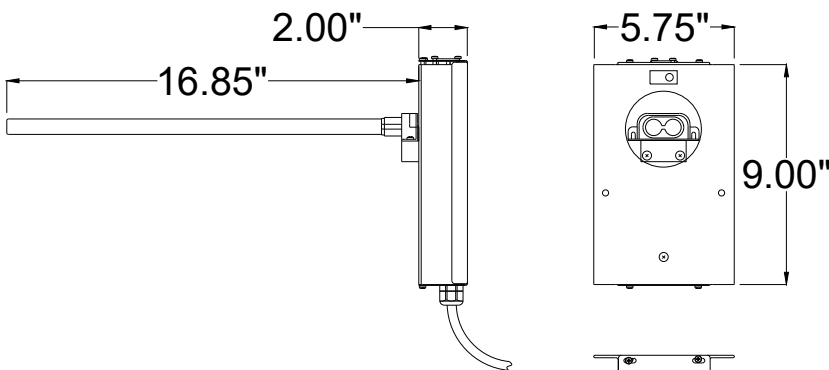
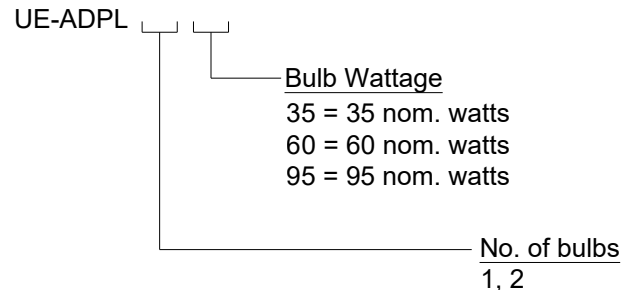

UE-ADPL-135/160/195

Due to continuing research, United Enertech reserves the right to change specifications without notice.

	3005 South Hickory Street Chattanooga, Tennessee 37407 Tel: (423) 698-7715 Fax: (423) 698-6629 www.unitedenertech.com			
	UE-ADPL Series Ultraviolet Light System			
DRAWN BY: CLJ	DATE: 1-6-21	REV. DATE: 4-19-21 VD	REV. NO. 2	DWG. NO.: Q-2